

# Stage Plot - One Horn Configuration

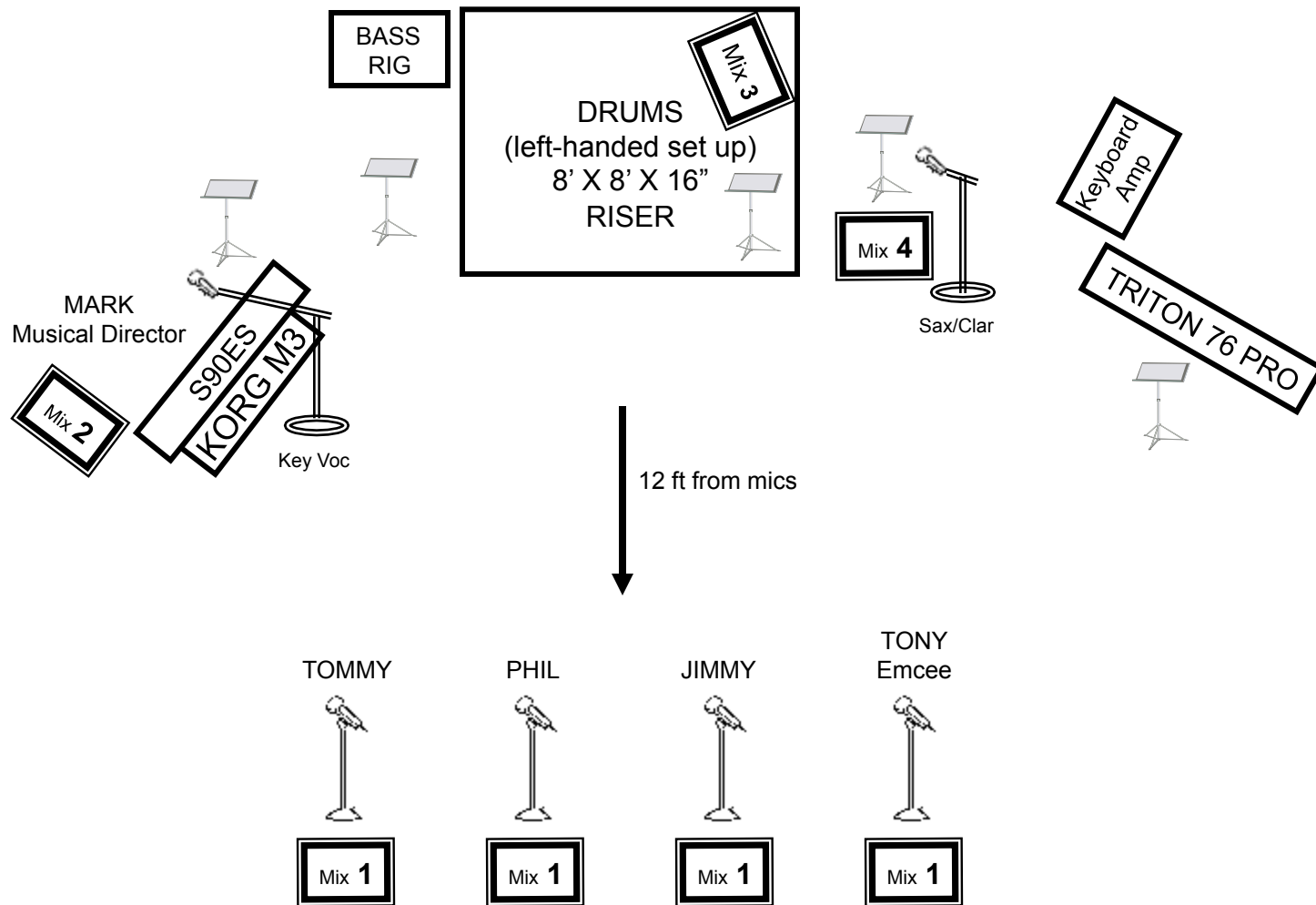

**NOTE: NOT TO SCALE**

**MIX 5, 6 & 7 FOR IN-EAR MONITORS**

**TOTAL MIXES REQUIRED: 7**

FOR QUESTIONS CONCERNING DUPREES STAGE PLOT CONTACT:  
 MARK BARON: (732)-310-7248 / MBARONMUSIC@GMAIL.COM



# Stage Plot - One Horn Configuration w/ Grand Piano

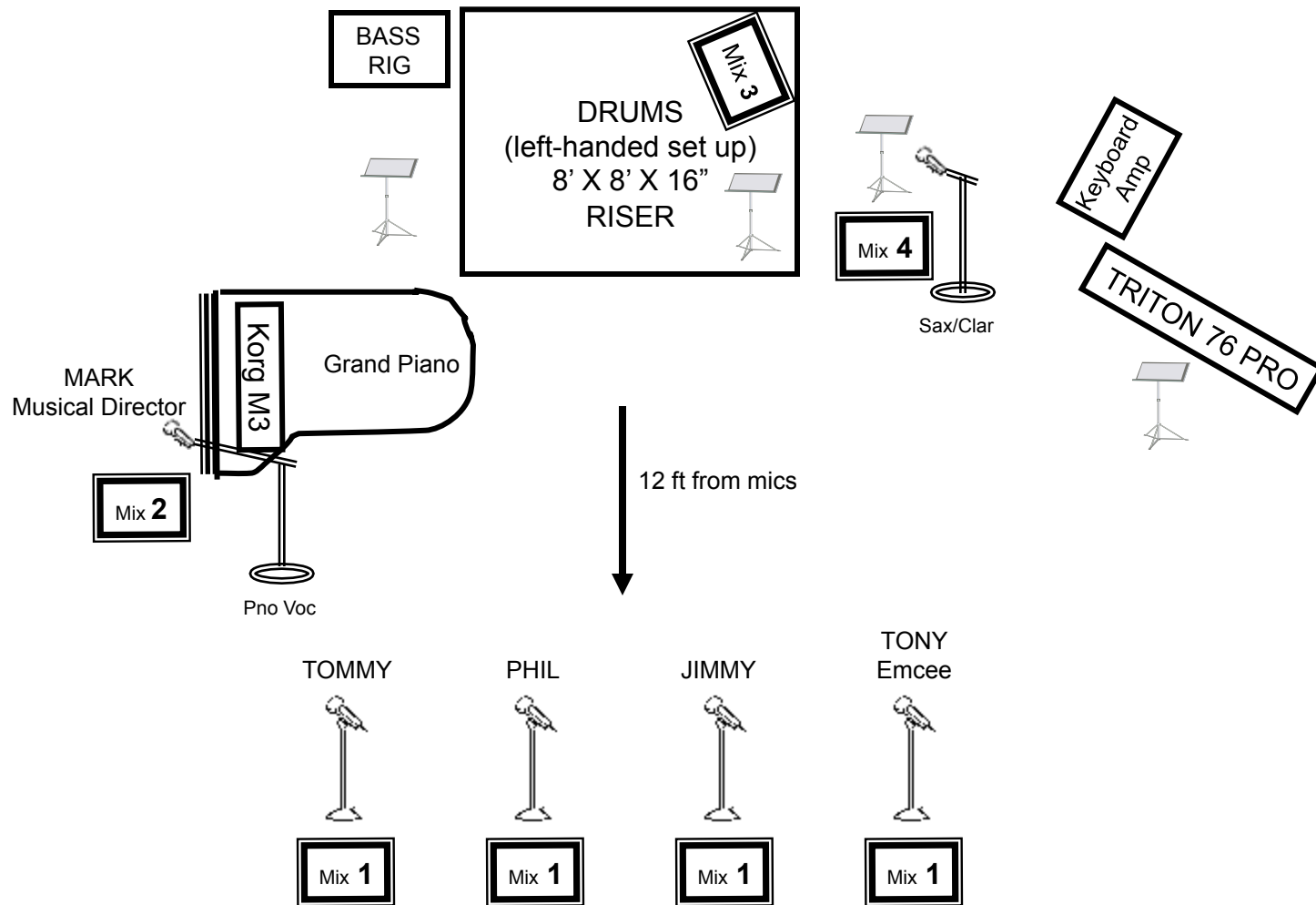

**NOTE: NOT TO SCALE**

**MIX 5, 6 & 7 FOR IN-EAR MONITORS**

**TOTAL MIXES REQUIRED: 7**

**FOR QUESTIONS CONCERNING DUPREES STAGE PLOT CONTACT:  
MARK BARON: (732)-310-7248 / MBARONMUSIC@GMAIL.COM**





**INPUT LIST**  
**1- HORN CONFIGURATION**

<b><u>CH</u></b>	<b><u>DESCRIPTION</u></b>	<b><u>MIC/DI</u></b>	<b><u>INSERT</u></b>	<b><u>STAND</u></b>
1	KICK	M-88 / BETA 52	COMP	short boom
2	SNARE TOP	SM57	COMP/GATE	short boom
3	HAT	SM81		short boom
4	RACK 1	SM98		claw
5	FLOOR TOM	SM98		claw
6	OH [L]	414 B/ULS		boom
7	OH [R]	414 B/ULS		boom
8	BASS RIG	DI (BSS AR 133)	COMP	
9	PIANO [top] or S90ES [L]	AKG C414 or DI		bridge
10	PIANO [bottom] or S90ES [R]	AKG C414 or DI		bridge
11	KORG M3-73 [L]	DI (BSS AR 133)		
12	KORG M3-73 [R]	DI (BSS AR 133)		
13	KORG TRITON 76 [L]	DI (BSS AR 133)		
14	KORG TRITON 76 [R]	DI (BSS AR 133)		
15	TENOR SAX/CLARINET	421		boom
16	STAGE VOCAL 1 (lead vocal)	UHF Beta 58	TUBE COMP	straight
17	STAGE VOCAL 2	UHF Beta 58	COMP	straight
18	STAGE VOCAL 3	UHF Beta 58	COMP	straight
19	STAGE VOCAL 4	UHF Beta 58	COMP	straight
20	PIANO VOCAL	Beta 58	COMP	boom
21	REVERB [L]			
22	REVERB [R]			
23	DELAY [L]			
24	DELAY [R]			

For questions concerning Duprees INPUT LIST contact:  
Mark Baron - (732) 310-7248 / Email: [mbaronmusic@gmail.com](mailto:mbaronmusic@gmail.com)

# Stage Plot - Three Horn Configuration

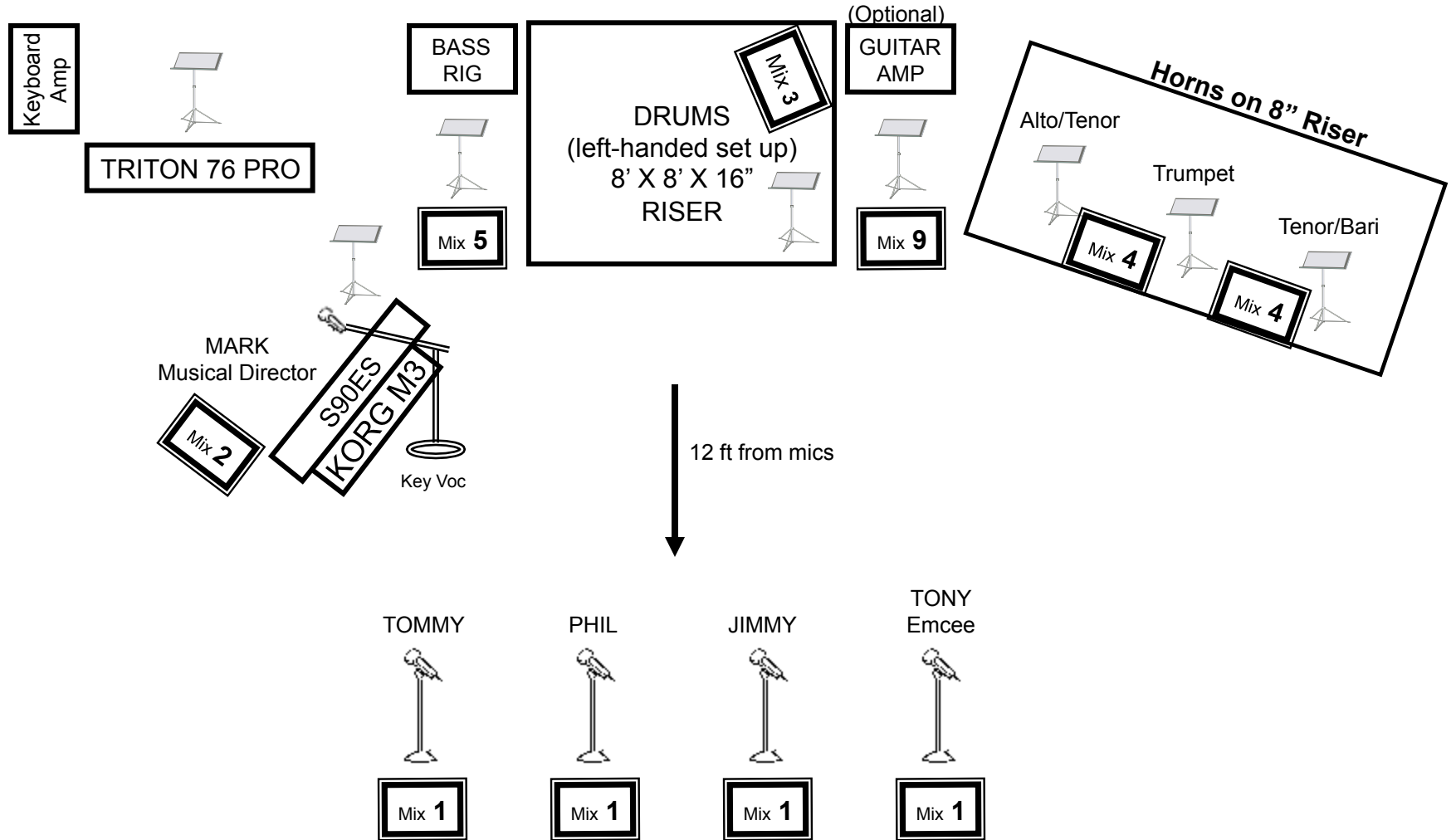

**NOTE: NOT TO SCALE**

**MIX 6, 7 & 8 FOR IN-EAR MONITORS**

**TOTAL MIXES REQUIRED: 8 (9 W/ OPTIONAL GUITAR)**

**FOR QUESTIONS CONCERNING DUPREES STAGE PLOT CONTACT:  
MARK BARON: (732)-310-7248 / MBARONMUSIC@GMAIL.COM**



# Stage Plot - Three Horn Configuration w/ Grand Piano

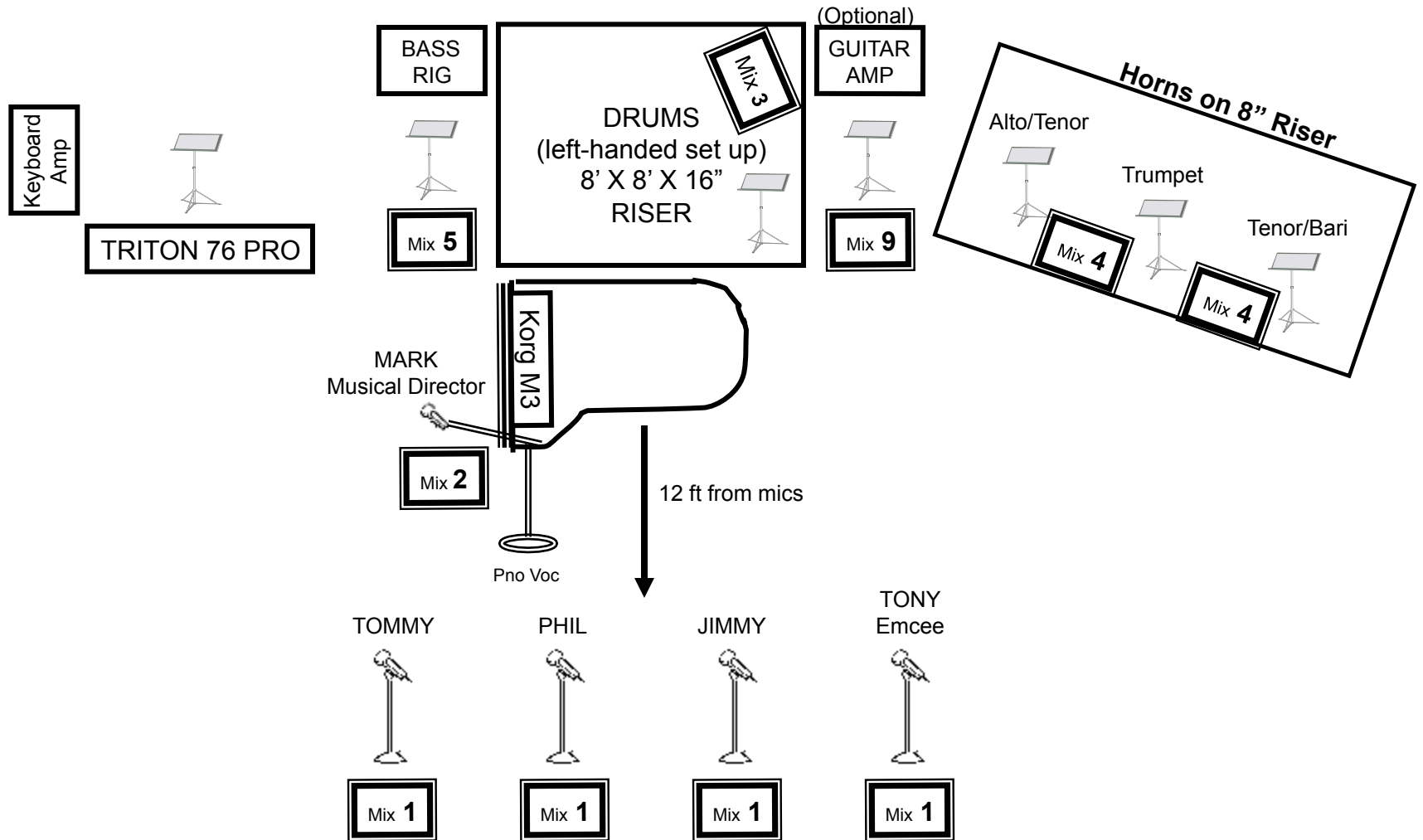

**NOTE: NOT TO SCALE**

**MIX 6, 7 & 8 FOR IN-EAR MONITORS**

**TOTAL MIXES REQUIRED: 8 (9 W/ OPTIONAL GUITAR)**

FOR QUESTIONS CONCERNING DUPREES STAGE PLOT CONTACT:  
MARK BARON: (732)-310-7248 / MBARONMUSIC@GMAIL.COM





**INPUT LIST**  
**3 – HORN CONFIGURATION**

<u>CH</u>	<u>DESCRIPTION</u>	<u>MIC/DI</u>	<u>INSERT</u>	<u>STAND</u>
1	KICK	M-88 / BETA 52	COMP	short boom
2	SNARE TOP	SM57	COMP/GATE	short boom
3	HAT	SM81		short boom
4	RACK 1	SM98		claw
5	FLOOR TOM	SM98		claw
6	OH [L]	414 B/ULS		boom
7	OH [R]	414 B/ULS		boom
8	BASS RIG	DI (BSS AR 133)	COMP	
9	FENDER TWIN (GUITAR)	409 or SM57		short boom
10	PIANO [top] or S90ES [L]	AKG C414 or DI		bridge
11	PIANO [bottom] or S90ES [R]	AKG C414 or DI		bridge
12	KORG M3-73 [L]	DI (BSS AR 133)		
13	KORG M3-73 [R]	DI (BSS AR 133)		
14	KORG TRITON 76 [L]	DI (BSS AR 133)		
15	KORG TRITON 76 [R]	DI (BSS AR 133)		
16	ALTO SAX/TENOR SAX	421		boom
17	TRUMPET 1	SM57		boom
18	TENOR SAX/BARI SAX	421		boom
19	STAGE VOCAL 1 (lead vocal)	UHF Beta 58	TUBE COMP	straight
20	STAGE VOCAL 2	UHF Beta 58	COMP	straight
21	STAGE VOCAL 3	UHF Beta 58	COMP	straight
22	STAGE VOCAL 4	UHF Beta 58	COMP	straight
23	PIANO VOCAL	Beta 58	COMP	boom
24	REVERB [L]			
25	REVERB [R]			
26	DELAY [L]			
27	DELAY [R]			

For questions concerning Duprees INPUT LIST contact:  
 Mark Baron - (732) 310-7248 / Email: [mbaronmusic@gmail.com](mailto:mbaronmusic@gmail.com)

## Stage Plot - Six Horn Configuration

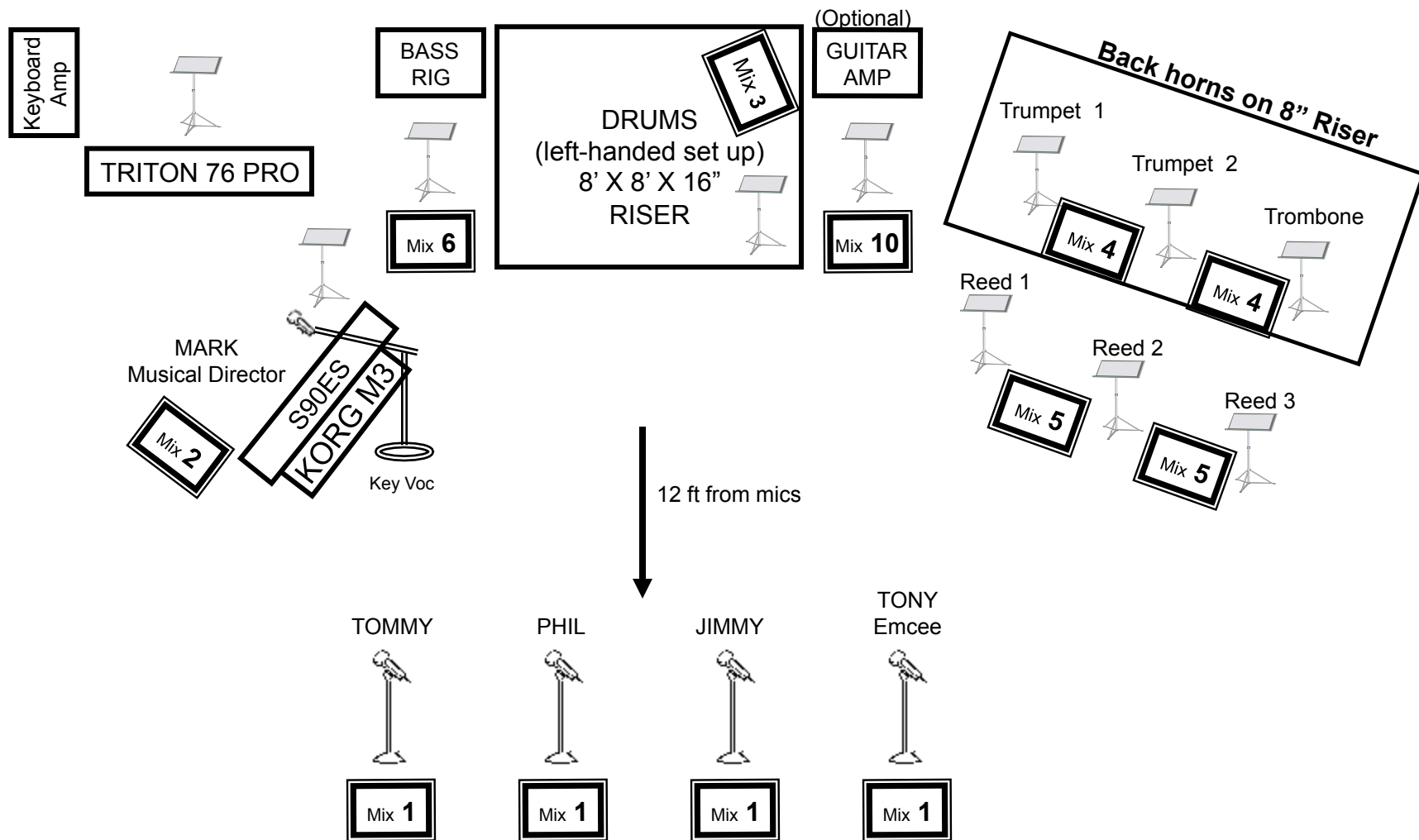

**NOTE: NOT TO SCALE**

**MIX 7, 8 & 9 FOR IN-EAR MONITORS**

**TOTAL MIXES REQUIRED: 9 (10 W/ OPTIONAL GUITAR)**

**FOR QUESTIONS CONCERNING DUPREES STAGE PLOT CONTACT:  
MARK BARON: (732)-310-7248 / MBARONMUSIC@GMAIL.COM**



# Stage Plot - Six Horn Configuration w/ Grand Piano

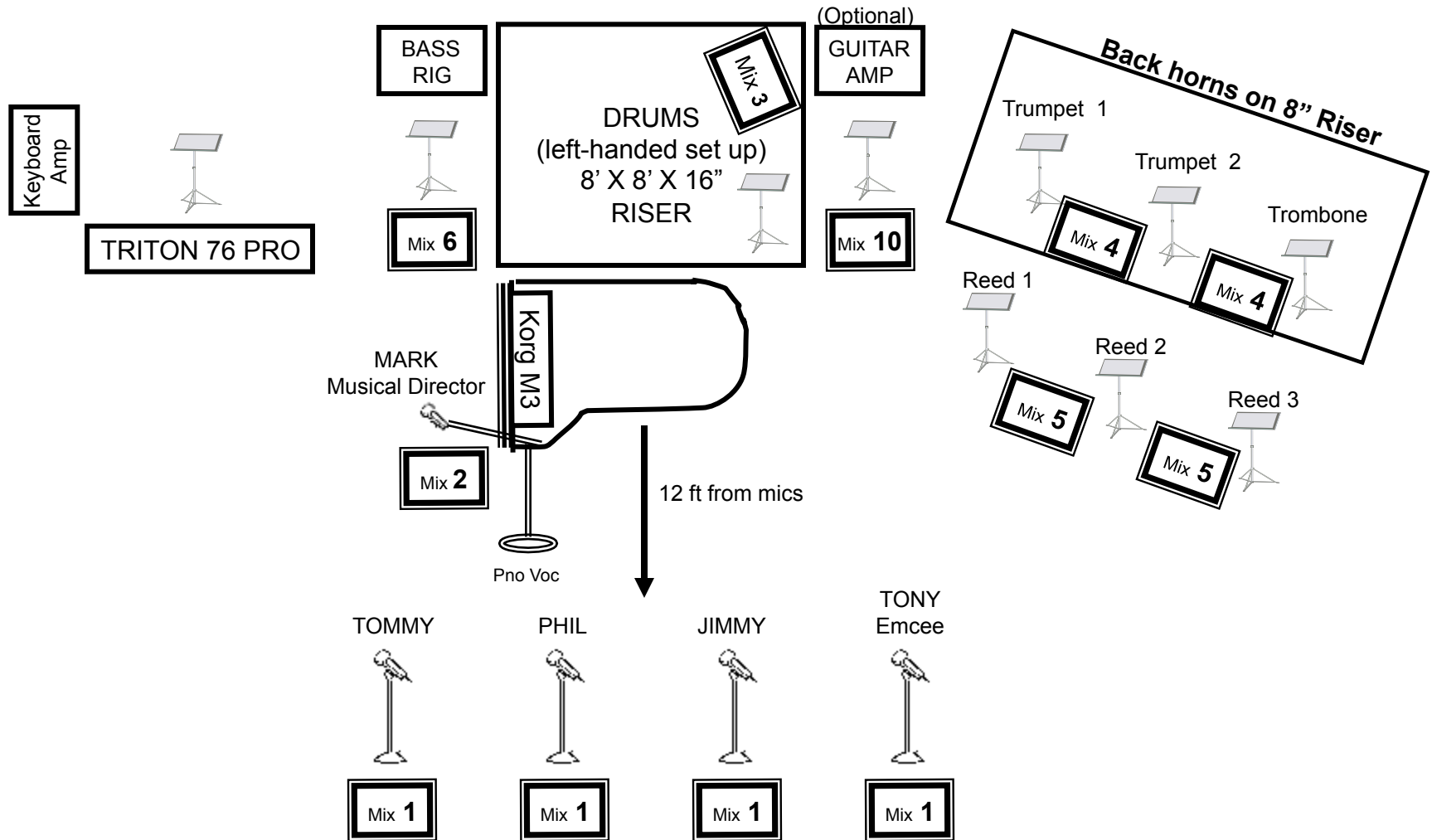

**NOTE: NOT TO SCALE**

**MIX 7, 8 & 9 FOR IN-EAR MONITORS**

**TOTAL MIXES REQUIRED: 9 (10 W/ OPTIONAL GUITAR)**

**FOR QUESTIONS CONCERNING DUPREES STAGE PLOT CONTACT:  
MARK BARON: (732)-310-7248 / MBARONMUSIC@GMAIL.COM**





**INPUT LIST**  
**6 – HORN CONFIGURATION**

<u>CH</u>	<u>DESCRIPTION</u>	<u>MIC/DI</u>	<u>INSERT</u>	<u>STAND</u>
1	KICK	M-88 / BETA 52	COMP	short boom
2	SNARE TOP	SM57	COMP/GATE	short boom
3	HAT	SM81		short boom
4	RACK 1	SM98		claw
5	FLOOR TOM	SM98		claw
6	OH [L]	414 B/ULS		boom
7	OH [R]	414 B/ULS		boom
8	BASS RIG	DI (BSS AR 133)	COMP	
9	FENDER TWIN (GUITAR)	409 or SM57		short boom
10	PIANO [top] or S90ES [L]	AKG C414 or DI		bridge
11	PIANO [bottom] or S90ES [R]	AKG C414 or DI		bridge
12	KORG M3-73 [L]	DI (BSS AR 133)		
13	KORG M3-73 [R]	DI (BSS AR 133)		
14	KORG TRITON 76 [L]	DI (BSS AR 133)		
15	KORG TRITON 76 [R]	DI (BSS AR 133)		
16	TRUMPET 1	SM57		boom
17	TRUMPET 2	SM57		boom
18	TROMBONE	441		boom
19	ALTO SAX/CLARINET	421		boom
20	TENOR SAX/CLARINET	421		boom
21	BARI SAX/CLARINET	421		boom
22	STAGE VOCAL 1 (lead vocal)	UHF Beta 58	TUBE COMP	straight
23	STAGE VOCAL 2	UHF Beta 58	COMP	straight
24	STAGE VOCAL 3	UHF Beta 58	COMP	straight
25	STAGE VOCAL 4	UHF Beta 58	COMP	straight
26	PIANO VOCAL	Beta 58	COMP	boom
27	REVERB [L]			
28	REVERB [R]			
29	DELAY [L]			
30	DELAY [R]			

For questions concerning Duprees INPUT LIST contact:  
Mark Baron - (732) 310-7248 / Email: [mbaronmusic@gmail.com](mailto:mbaronmusic@gmail.com)